

AQS

AQUASPIRIT



UKRAINIAN SHIPBUILDING COMPANY

S700	4
S585	6
S530	8
S450	10
S370	12
S290-350	14



AQUASPIRIT

Aquaspirit is a Ukrainian shipbuilding company specializing in the production of high-quality aluminum RIB-class boats. We manufacture reliable, durable vessels that combine innovative design, comfort, and excellent performance. Our team brings together leading industry professionals and applies modern design and manufacturing technologies to develop models that meet current market demands. Top quality and safety are our absolute priorities: each boat is certified according to EU standards and marked with the CE label. Continuously improving our design solutions, we focus on customer needs and offer models that serve equally well for active leisure and professional use.



SPIRIT 700

Aquaspirit S700 is the flagship model from AQUASPIRIT, featuring a modern, dynamic design and outstanding seaworthiness. This RIB boasts a fully aluminum hull and D-shaped tube, which significantly increases internal space, comfort, and safety compared to competitors. With an engine of up to 300 HP, it can reach speeds of up to 100 km/h, delivering impressive handling and superb performance on the water. Thanks to a spacious cockpit with seating for 11 passengers and generous storage compartments, the Spirit 700 is ideal for cruising, watersports, or relaxed outings. The model is available in various configurations and can be additionally equipped with a fridge, table, sunbeds, sunshade, portable toilet, compact galley, shower system, and more.





TECHNIACAL DAT

S700

Length o.a	6,99 m.
Width o.a	2,85 m.
Draft (base load)	0,5 m.
Capacity	11 ppl.
Max. engine power	300 h.p.
Max.speed (unloaded, 2 pass.)	90 km/h.
Shaft length	25/635 (XL) mm.
Fuel tank capacity	300 l.
Max. load	1031 kg.
Bare weight	1160 kg.
Payload	1602 kg.
Loaded displacement mass	2890 kg.
Hull material	EN AW 5083 H111
Category	C

SPIRIT *585*

Aquaspirit S585 is a perfect blend of top-tier performance and comfort in a compact form. Fast, agile, and exceptionally stable even in turns or rough waters, the S585 ensures a smooth and confident ride. Every detail is designed with comfort in mind: a well-organized deck, cushioned seating, and ample storage space for personal belongings. This boat opens up a world of adventure — from energetic water sports to leisurely coastal cruising. The S585 comes in two versions and can be configured either with a central console or dual side consoles. It can also be equipped with a sunshade, extended bow seating, a table, navigation arch, engine guard, and other custom features.



**TECHNICAL DATA****S585CC/DC**

Length o.a	5,88 m.
Width o.a	2,55 m.
Draft (base load)	0,43 m.
Capacity	8 ppl.
Max. engine power	150 h.p.
Max.speed (unloaded, 2 pass.)	82 km/h.
Shaft length	25"/ XL/ 635 mm.
Fuel tank capacity	132 lit.
Max. load	CC-667/DC-648 kg.
Bare weight	CC-744/DC-763 kg.
Payload	CC-1095/DC-1114 kg.
Loaded displacement mass	1854 kg.
Hull material	EN AW 5083 H111
Category	C

SPIRIT *530*

Aquaspirit S530 is a stylish and comfortable 5-meter RIB that combines agility, stability, and smart design. With space for up to 7 passengers, it's perfect for parties, waterskiing, wakeboarding, sunbathing, or just relaxing on the water. Built with a durable 4 mm marine-grade aluminum hull, the S530 features a sleek, V-shaped hull and wide stern that ensure excellent seaworthiness and impressive performance. Paired with a 100 HP engine, it can reach speeds of up to 70 km/h. Easy to transport and launch, the S530 is an ideal boat for leisure. It's available with either a central or twin-console layout, and also comes in professional configurations for police, fire-fighting, and search-and-rescue operations.



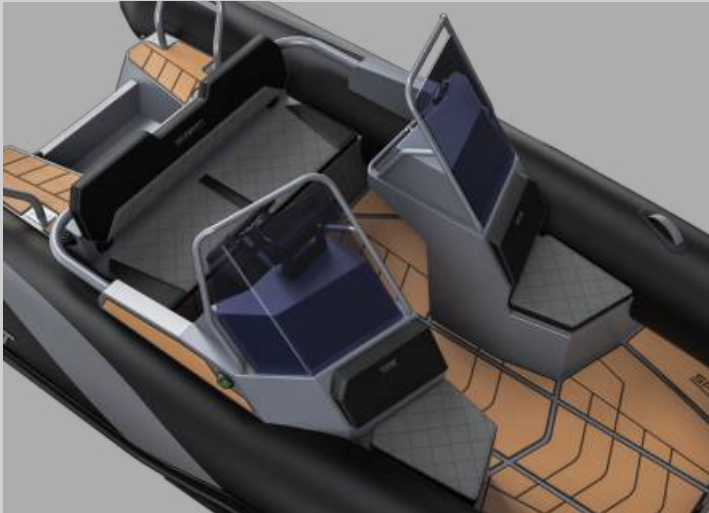
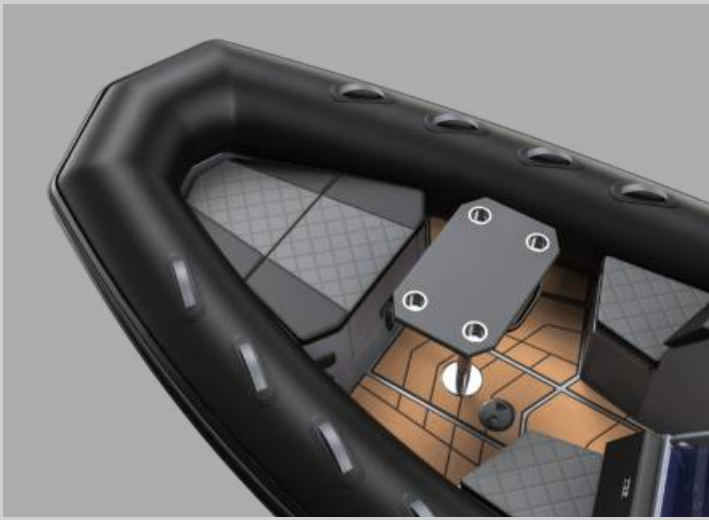

TECHNICAL DATA

S530

Length o.a	5,3 m.
Width o.a	2,31 m.
Draft (base load)	0,37 m.
Capacity	7 ppl.
Max. engine power	100 h.p.
Max.speed (unloaded, 2 pass.)	80 km/h.
Shaft length	20"/L/508 mm.
Fuel tank capacity	62 lit.
Max. load	1000 kg.
Bare weight	389 kg.
Payload	642 kg.
Loaded displacement mass	1538 kg.
Hull material	EN AW 5083 H111
Category	C

SPIRIT 450

Aquaspirit S450 is the ideal entry-level boat for leisure and recreation, easily transportable on a trailer. It combines the compact size and simplicity of construction with the advantages of larger Aquaspirit models. The boat comfortably accommodates four passengers, with a maximum capacity of six. Storage compartments under all seats add convenience during longer trips. The double-walled aluminum hull is equipped with an automatic bilge pump for added safety. Powered by an economical 60 HP engine, the S450 reaches speeds over 60 km/h. With an optional stern arch, it's great for waterskiing and towing inflatables. Thanks to its ability to plane with just a 15 HP petrol or 6 kW electric motor, it can be operated license-free in many regions. The model is also available without a console and in a professional version tailored for emergency services.



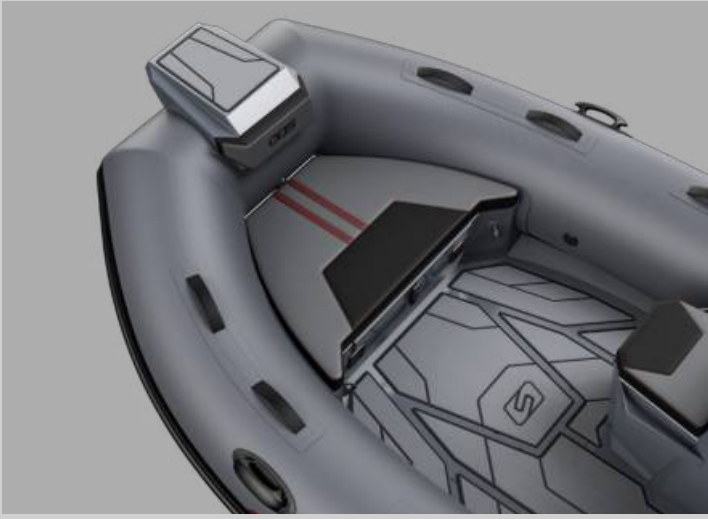

TECHNICAL DATA

S450

Length o.a	4,42 m.
Width o.a	2,14 m.
Draft (base load)	0,3 m.
Capacity	6 ppl.
Max. engine power	75 h.p.
Shaft length	20"/L/508 mm.
Fuel tank capacity	43 lit.
Max. load	793 kg.
Bare weight	212 kg.
Payload	390 kg.
Loaded displacement mass	981 kg.
Hull material	EN AW 5083 H111
Category	C

SPiRiT 370

Aquaspirit S370 is a fast and agile tender with a unique design. This boat combines compact external dimensions with an impressive 1.20 m-wide cockpit, comfortably accommodating up to four people. It comes equipped with a console featuring a windscreen, perimeter handrails, and plenty of storage space for personal belongings. A key feature of the S370 is its special foldable mechanism for tender garage storage – an ideal solution for yacht owners. The boat is fitted with a built-in 40-liter aluminum fuel tank, enabling long trips without refueling. A wide bow platform ensures easy access to the cockpit, while the open deck layout allows for either a central or side console configuration. The S370 is standard-equipped with a removable ski mast for watersports and can also be fitted with stern platforms featuring an integrated folding ladder.





TECHNICAL DATA

S370

Length o.a	3,657 m.
Width o.a	1,89 m.
Draft (base load)	0,3 m.
Capacity	4 ppl.
Max. engine power	60 h.p.
Shaft length	20"/L/508 mm.
Fuel tank capacity	40 lit.
Max. load	300 kg.
Bare weight	340 kg.
Payload	543 kg.
Loaded displacement mass	870 kg.
Hull material	EN AW 5083 H111
Category	C

SPIRIT *290-350*

Aquaspirit tender series stand out for their light weight, durability, and versatility. Each model is available in a variety of configurations, including side or sporty steering consoles. Customers can also choose from different tube materials (PVC or Hypalon Orca) and color options. All boats feature an open cockpit layout and come equipped with an under-deck fuel channel. An optional bow platform can be installed to facilitate boarding and docking. These models are ideal for both fishing enthusiasts and families enjoying coastal cruising. The S350 supports engines up to 30 HP, making it a practical solution for towing water skis or a wakeboard.

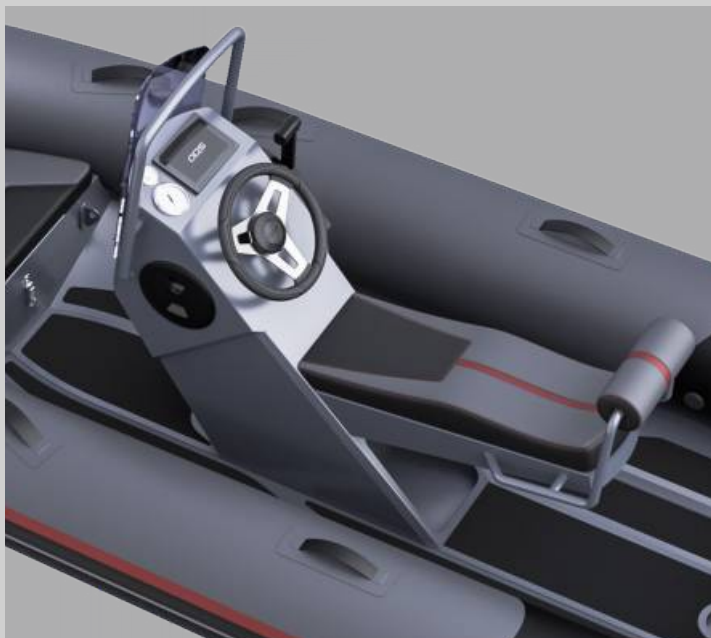

**TECHNICAL DATA**

	S290/290C	320	S350/350C
Length o.a	2,88 m.	3,15 m.	3,49 m.
Width o.a	1,59 m.	1,68 m.	1,68 m.
Draft (base load)	0,24 m.	0,24 m.	0,24 m.
Capacity	3 ppl.	3+1 ppl.	4 ppl.
Max. engine power	11 h.p.	15 h.p.	30 h.p.
Shaft length	15"/S/381 mm.	15"/S/381 mm.	15"/S/381/ 20"/L/508 mm.
Fuel tank capacity	25 lit.	25 lit.	25 lit.
Max. load	389 kg.	441 kg.	381/361 kg.
Bare weight	62 kg.	71 kg.	78/98 kg.
Payload	132 kg.	141 kg.	217/237 kg.
Loaded displacement mass	451 kg.	512 kg.	598/618 kg.
Hull material	EN AW 5083 H111	EN AW 5083 H111	EN AW 5083 H111
Category	C	C	C



AQUASPIRIT LLC

Kyiv, Ukraine

+38 044 351 75 89

info@aquaspirit.com.ua

www.aquaspirit.boats